

**Formed Steel Louver ▲ 7" Deep ▲ Combination ▲ 35° Drainable Blades ▲ Acoustical / Insulated Adjustable Blades**

**STANDARD MATERIALS AND CONSTRUCTION**

**FRAME:** 16-GA. galvanized steel.

**BLADE:** Stationary blades made from 18-GA. galvanized steel. Adjustable blades made from 18-GA. galvanized steel, double thickness, 1" thick with 8 lbs. density mineral wool insulation, sandwiched between metal skins separated by a thermal break and mechanically fastened together. Blades are approximately 3" on centers.

**LOUVER FACE:** Full head and sill with blades and jambs contained within.

**LINKAGE:** Brackets are 12-GA. Zinc plated machined steel. Pivots are .50" dia. machined steel, Zinc plated. Pivots rotate in a Celcon bearing. A .312" dia. aluminum linkage rod is locked to the pivot by a ¼ - 20 set screw with an epoxy patch.

**SEALS:** Neoprene adhesive applied to blade edges and jambs.

**SHAFTS:** ½" dia. plated steel stub.

**BEARINGS:** ½" dia. bore oilite bronze flanged sleeve. Press fit into frame.

**SCREEN:** (Secured to the exterior)  
 ½" flattened aluminum (.051"),  
 -or- ½" sq. mesh 19-GA. galvanized steel (.041"),  
 -or- 1⅞" aluminum mesh insect screen (.011" dia.)

**FINISH:** Mill.

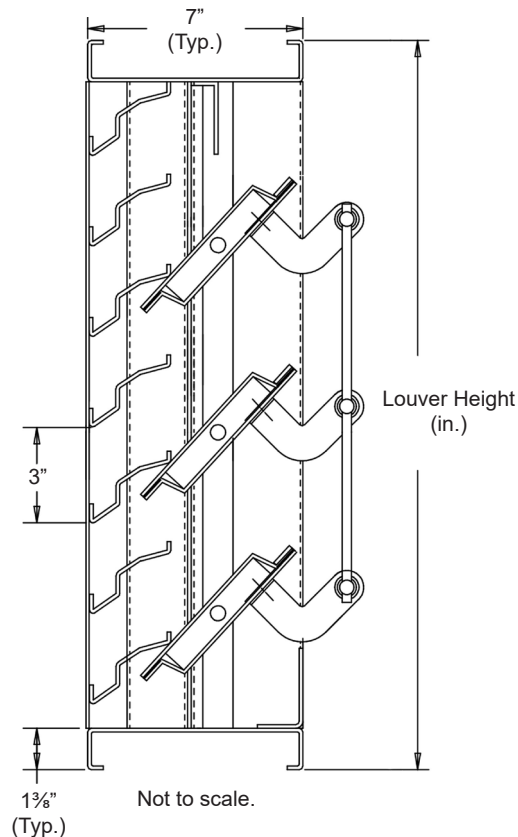

**OPTIONS**

Finishes - Enamels, Epoxies, etc.

Other screens also available.

Actuators - Electric, Pneumatic, Manual, etc.

**NOTES**

1. Nominal deductions will be made to the opening sizes given.
2. Approximate shipping weight is 11 lbs./sq.ft.

**LOUVER SIZES**

Min Panel	Max Single Panel
12"W x 14"H	48"W x 96"H

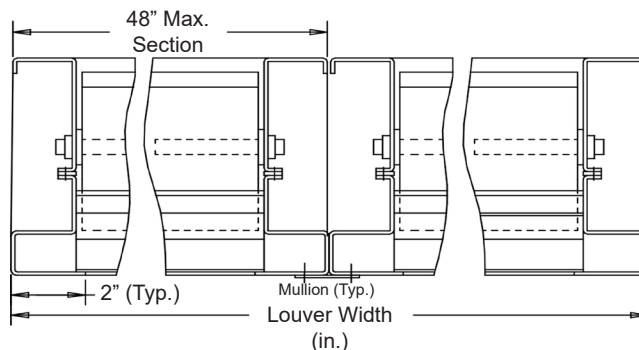
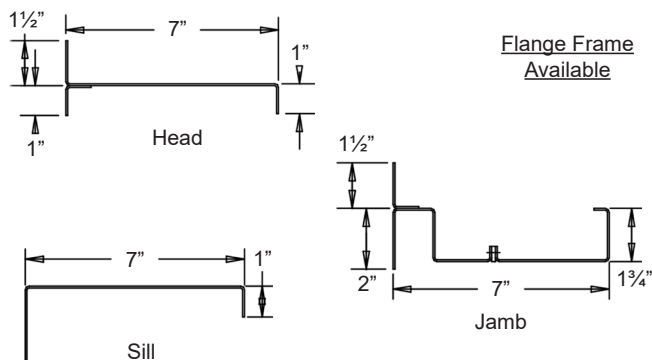

Item #	Qty	Width	Height	Width	Height	Mullion	Type	Location	Screens	Union Made
		Opening Size		Louver Size						
Arch. / Eng. :						EDR:		ECN:		Job:
Contractor:										
Project:						Date:		DWN:		DWG:



**Formed Steel Louver ▲ 7" Deep ▲ Combination ▲ 35° Drainable Blades ▲ Acoustical / Insulated Adjustable Blades**

**PERFORMANCE DATA**

Pressure Drop: .17 in. w.g. at 1000 fpm (intake) | .12 in. w.g. at 1000 fpm (exhaust)

Free Area: 7.26 sq.ft. = 45.4% for 48"W x 48"H sample tested in accordance with AMCA Standard 500-L

Beginning Point of Water Penetration: 841 fpm

Ratings do not include the effects of a screen.

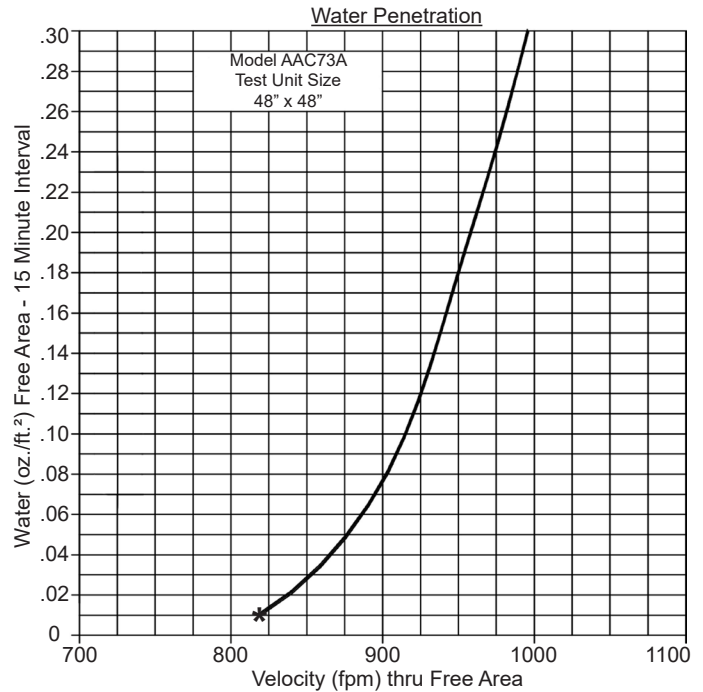
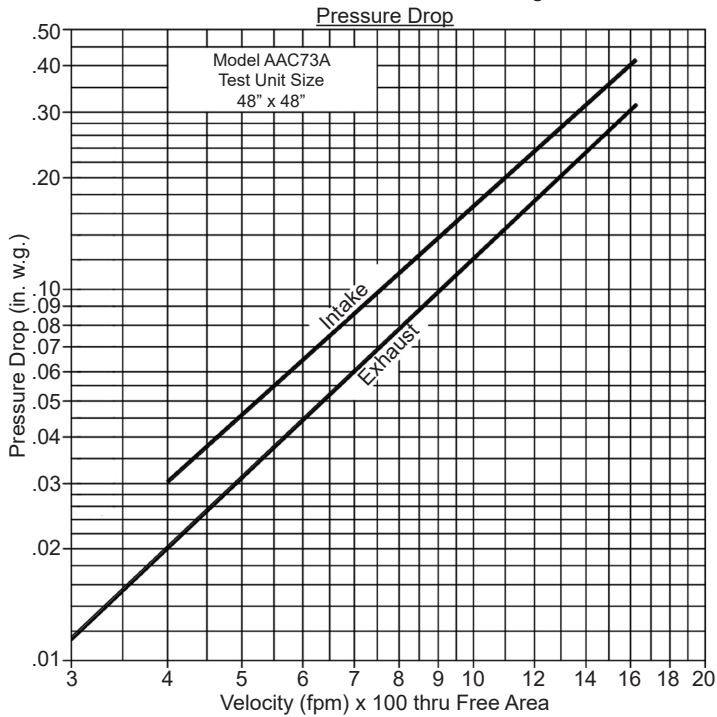

841 (FPM) Beginning Point of Water Penetration.

Intake air converted to standard air density.  
Tested to AMCA Standard 500-L, Figure 5.5.

**Free Area (sq. ft.)**

Height (in.)	Width (in.)						
	12"	18"	24"	30"	36"	42"	48"
12"	.22	.38	.54	.70	.85	1.01	1.17
24"	.61	1.04	1.47	1.91	2.34	2.77	3.20
36"	1.00	1.70	2.41	3.11	3.82	4.52	5.23
48"	1.39	2.37	3.34	4.32	5.30	6.28	7.26
60"	1.77	3.03	4.28	5.53	6.78	8.04	9.29
72"	2.16	3.69	5.21	6.74	8.27	9.79	11.32
84"	2.55	4.35	6.15	7.95	9.75	11.55	13.35
96"	2.94	5.01	7.08	9.16	11.23	13.30	15.38

**Acoustic Values**

Octave Band / Hz	Noise Reduction (dB)
1 / 63	9
2 / 125	8
3 / 250	7
4 / 500	8
5 / 1000	10
6 / 2000	15
7 / 4000	15
8 / 8000	16

**Attenuation**

Octave Band Center Frequency (Hz)

Height	1	2	3	4	5	6	7	8
	(63)	(125)	(250)	(500)	(1000)	(2000)	(4000)	(8000)
10'	15	14	13	14	14	17	18	20
50'	29	28	27	28	28	31	32	34
100'	35	34	33	34	34	37	38	40
200'	41	40	39	40	40	43	44	46
500'	49	48	47	48	48	51	52	54
1000'	55	54	53	54	54	54	57	60

**Thermal Characteristics**

Insulating factors for the standard blade construction:

R-Value: 3.9

U-Factor: .26 BTU per hour per sq. ft. per degree F.

The above values are based on calculations considering face area of the louver only. This does not include frames. Insulation of the frame and caulking louver into opening shall be by others.

Attenuation chart above is a combination of the louver sound transmission loss and the reduction of sound energy as a function of distance from the noise source.